

Spoločnosť: _____ Telefón: _____

Meno: _____ Email: _____

Adresa: _____ Číslo stroja: _____

Typ manžety: štandardný tvar kónický tvar(k) počet ks: _____

Lmax: _____ mm

Lmin: _____ mm

priemer Ds1 _____ mm

priemer Ds2 _____ mm

priemer Da _____ /k mm

priemer DI _____ /k mm

rozmer b1 _____ mm

rozmer b2 _____ mm

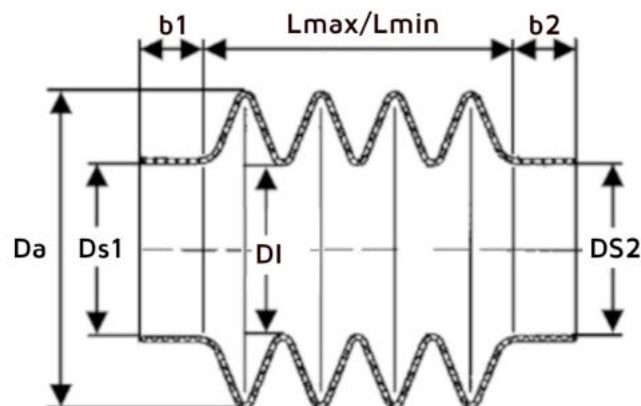

chemická odolnosť proti:

chl.kvapalina: _____

prach: _____

ostatné: _____

teplota: _____ °C

počet ks: _____

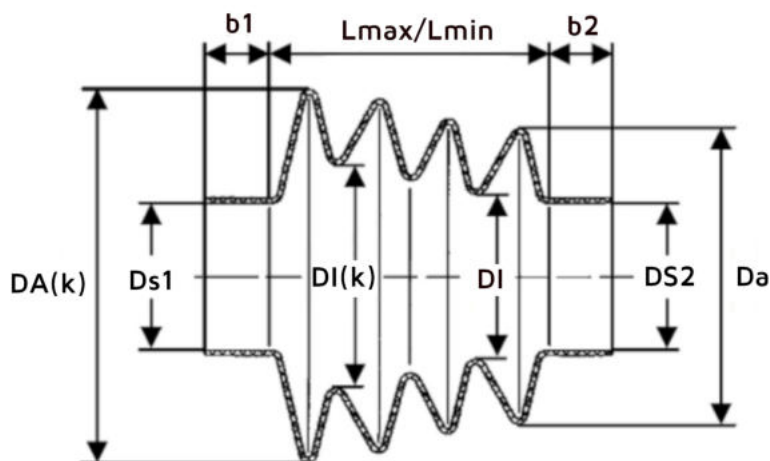

Materiál manžety: NBR NR CR EPDM Si

Možnosti upevnenia pomocou:

spony

podložky a skrutky

podložky a skrutky

nákrúžku, alebo príruby

